

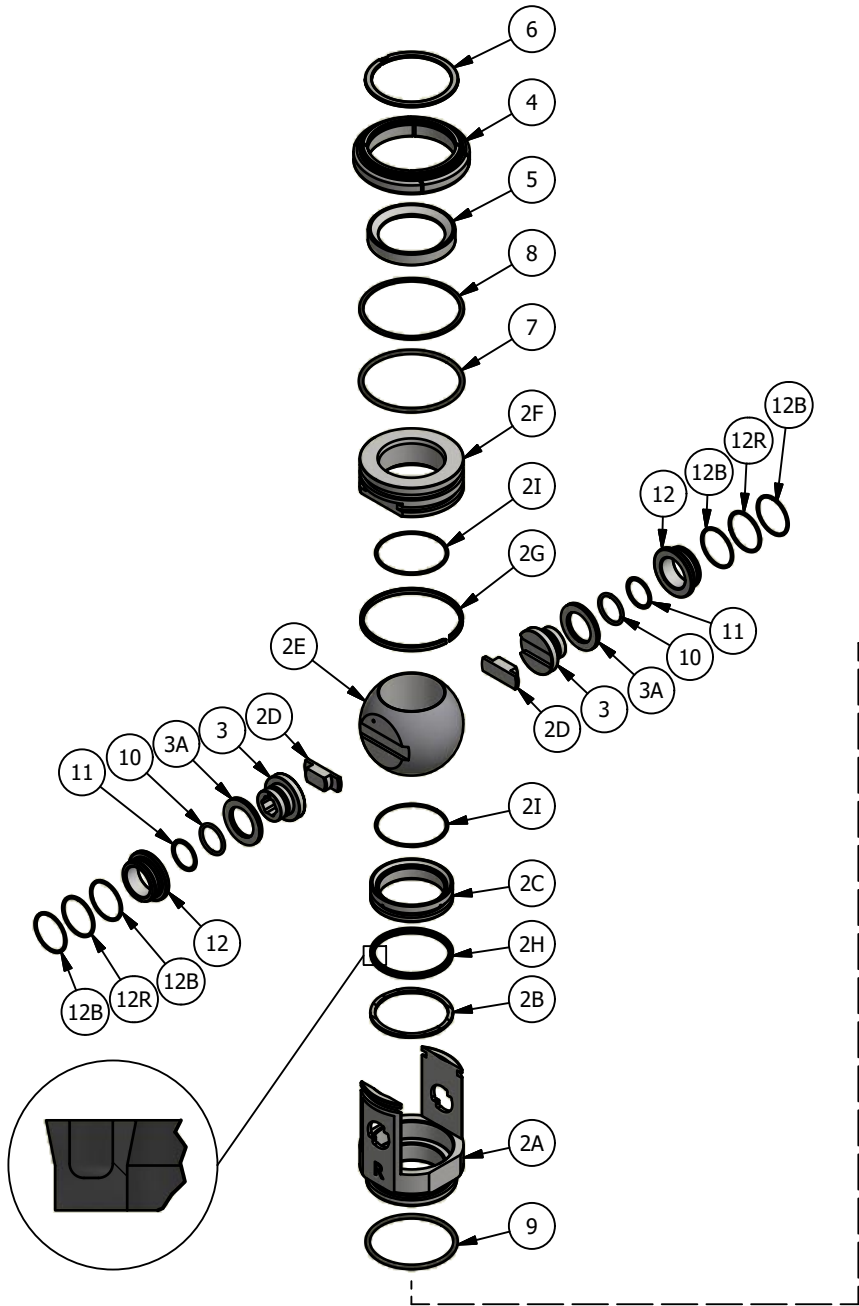

CANISTER GUARD REMOTE UPPER WELL CONTROL VALVE FOR CANRIG ACTUATOR

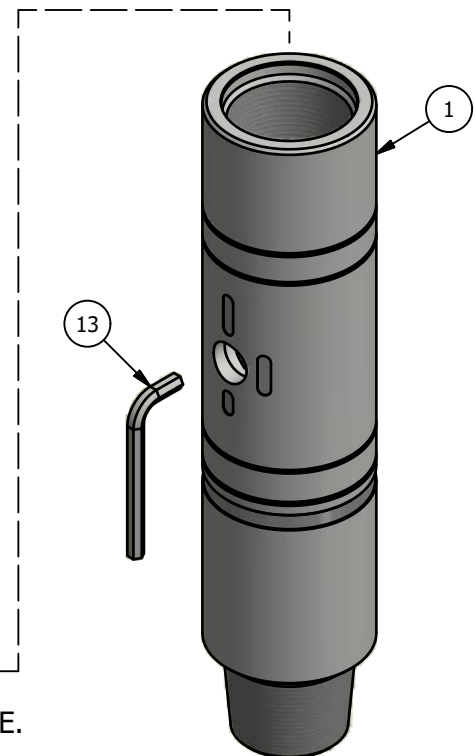

PARTS LIST		
ITEM	QTY	DESCRIPTION
1	1	VALVE BODY
2	1	COMPLETE CANISTER ITEMS 2A-2I, 7, 8, 9
2A	1	CAGE
2B	1	SPRING
2C	1	LOWER SEAT
2D	2	STEM LINK
2E	1	BALL
2F	1	UPPER SEAT
2G	1	CAGE/SEAT FASTENER
2H	1	LOWER SEAT SEAL (LIP SEAL)
2I	2	UPPER/LOWER SEAT TEFLON RING
3	2	STEM
3A	2	THRUST BEARING
4	1	LOCKING SEGMENTS
5	1	SUPPORT RING
6	1	SPIRAL RETAINER RING
7	1	UPPER SEAT O-RING
8	1	UPPER SEAT BACK-UP RING
9	1	CANISTER O-RING
10	2	STEM O-RING
11	2	STEM BACK-UP RING
12	2	STEM BUSHING
12R	2	STEM BUSHING O-RING
12B	4	STEM BUSHING BACK-UP RING
13	1	WRENCH
14		MAJOR SEAL KIT ITEMS 2H, 2I, 7, 8, 9, 10, 11, 12R, 12B
15		MAJOR PARTS KIT ITEMS 2, 3, 3A, 10, 11, 12, 12R, 12B



NOTES:

- 1) THIS ASSEMBLY IS ONLY APPLICABLE TO THE 3-06 CANISTER SIZE.
- 2) ITEMS 12, 12R, 12B MAY NOT APPLY TO ALL ASSEMBLIES. CHECK WWW.MMVALVE.COM FOR APPROPRIATE PARTS LIST BASED ON VALVE SERIAL NUMBER.